

**Casambi Ready constant current independent dimmable driver
WAL(S) Series suffix WCN(Casambi Wireless+NFC programmable)**

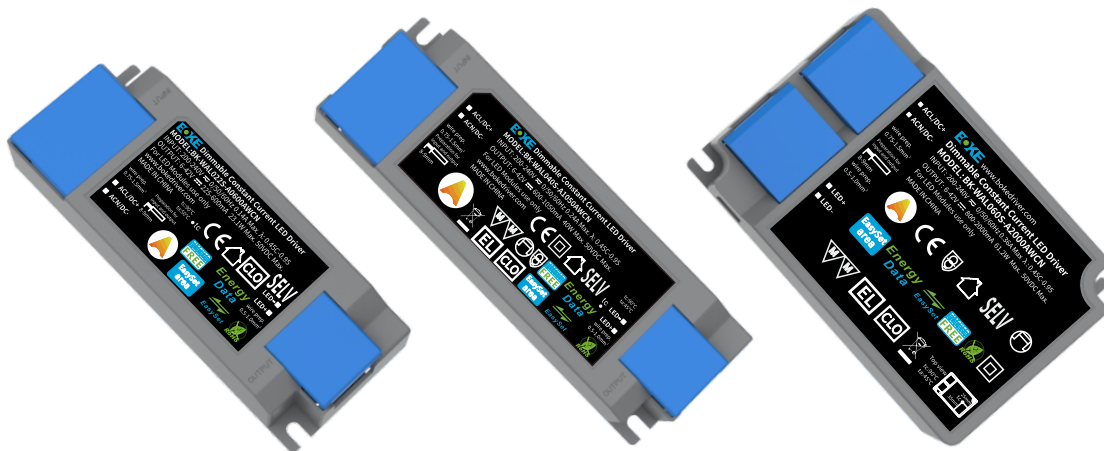

Features

- Integrated Casambi wireless module for the Casambi wireless ecosystem
- Support reading EnergyData through Casambi network (Luminaire data, Energy reporting and diagnostics & maintenance)
- Support Casambi wireless Long Range(LR) mode network
- Support advanced functions such as EL, CLO
- The output current and more functions of the driver can be realized through the NFC interface
- Supports Change profile to switch the dimming curve
- Supports quick construction of Casambi networks with up to 250 devices
- Casambi wireless mesh networking, stable work
- Support for over-the-air firmware updates with Casambi APP
- Soft dimming and flicker-free at any brightness, meets the new requirements of ErP certification
- Using HPC patented technology, the brightness of the luminaire is the same at any dimming level
- Dimming range 1~100%, soft dimming process
- High PF, high efficiency, low THD
- SELV and Class II design, suitable for use outside of the luminaire
- Compliance with CE,EL and other certifications
- IP20 protection grade, indoor use
- Nominal life-time up to 100,000 h
- 5.5-year guarantee

Functions

- Support central emergency application(Can be configured for normal dimming or fixed brightness output in DC input)
- Support self-contained emergency application
- Casambi Wireless control system
- Emergency lighting(EL)
- Constant light output function(CLO)
- Programming via NFC(EasySet)
- Protective features (short-circuit,overload protection)

Suitable for lights

- Suitable for lights with independent drivers such as downlights, spotlights, panel lights, etc

Typical applications

- LED indoor lighting
- LED office lighting
- LED commercial lighting

Model coding rules of WAL(S) series

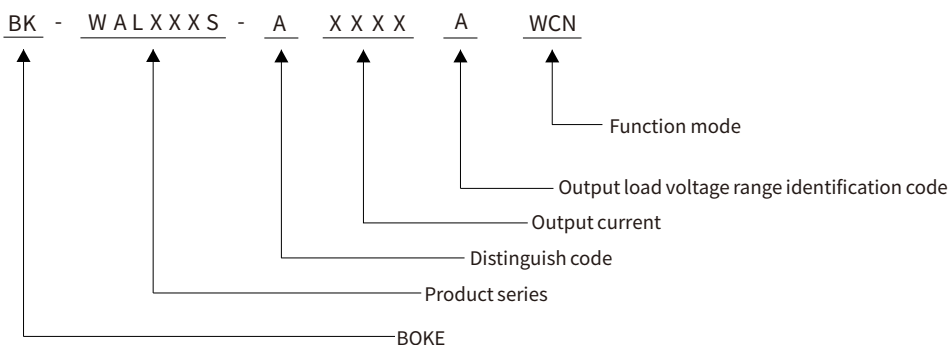

Function list

Model	Suffix	DIP switch	EL (DC input)	Wireless dimming	Advanced functions			Device Configuration
				Casambi Wireless	AOC	CLO	EL (configurable)	NFC interfaces
BK-WAL022S-A BK-WAL040S-A	WC	√	√	√				
BK-WAL060S-A	WCN		√	√	√	√	√	√

*The description in this specification is only applicable to the products with the suffix WCN and the model are WAL022S-A, WAL040S-A, WAL060S-A.

Model list

Model	Input voltage	Output power	Output voltage	Output current	Dimension
BK-WAL022S-A0600AWC	200-240VAC/DC	23.1W MAX.	6-42VDC	0.225-0.6A	L117*W45.5*H29mm
BK-WAL022S-A0600AWCN	200-240VAC/DC	23.1W MAX.	6-42VDC	0.225-0.6A	L117*W45.5*H29mm
BK-WAL040S-A1050AWC	200-240VAC/DC	40W MAX.	6-42VDC	0.60-1.05A	L137*W46*H30mm
BK-WAL040S-A1050AWCN	200-240VAC/DC	40W MAX.	6-42VDC	0.60-1.05A	L137*W46*H30mm
BK-WAL060S-A2000AWC	200-240VAC/DC	61.2W MAX.	6-42VDC	0.80-2.00A	L123.5*W79.5*H31mm
BK-WAL060S-A2000AWCN	200-240VAC/DC	61.2W MAX.	6-42VDC	0.80-2.00A	L123.5*W79.5*H31mm

*The description in this specification is only applicable to the products with the suffix WCN and the model are WAL022S-A, WAL040S-A, WAL060S-A.

Technical data

Product model	BK-WAL022S-A0600AWCN
Output parameters	
Regulation method	Constant Current
Rated output current range	0.225-0.6A,see the operating window for details
Rated output voltage range	6-42VDC,see the operating window for details
Rated output power	23.1W Max,see the operating window for details
Output current adjustment	EasySet programming
Output current ripple LF	±2%
Output current accuracy	±2%
Linear regulation	±1%
Load regulation	±1%
No load output voltage	50VDC
Flicker-free(typical)	Flickering percent(IEEE 1789)=0.184%(100Hz), Flicker index(IEEE 1789)=0.003(100Hz), Pst LM = 0.000, SVM = 0.004, (The above parameters are obtained from testing the panel lights)
Input parameters	
Rated input voltage range	200-240VAC 200-240VDC
Input voltage range	180-264VAC 180-264VDC
Input voltage shock	<380 V AC
Input current	<0.14A (Rated input voltage)
Input frequency	0/50/60Hz
Input PF/Input DF(typical)	PF: 0.98, DF:0.98 ,see the electrical values below for details
Input THD(typical)	8% ,see the electrical values below for details
Efficiency(typical)	86% ,see the electrical values below for details
In-rush current(typical)	6.28A peak ,206us duration(50 % Ipeak), see the description below for details
Switching cycles	> 100,000 switching cycles
Power consumption(typical)	Full load(Pin):26.9W, No load(Pno): N/A, On stand-by(Psb) : <0.5W, Network stand-by(Pnet) : N/A
Safety	
Withstand voltage	I/P-O/P(LED):3750V AC
Mains surge capability	L-N:2KV(90°/270° , 5 times each with an interval of 60s)(Performance criterion:A)
Leakage current(typical)	0.34mA
Isolation resistance	I/P-O/P:100MΩ/500Vdc/25°C/70% RH
Wireless features	
Control system	Casambi Ready
Bluetooth version	Bluetooth 5.3
Transmission power	8 dBm
Reception sensitivity	-96dBm
Frequency range:	2.402 – 2.480 GHz
Dimming output	
Dimming range	1-100%
Dimming drive mode	AM(amplitude modulation)
Emergency support	
Central emergency system	Supported
Self-contained emergency	Supported
Environment & Life time	
Operating temperature	Ta=-20-50°C
Case temperature	Tc=90°C
Operating humidity	5-85% RH, not condensed
Storage temp./humidity	-40-80°C, 5-85% RH, not condensed
IP rating	IP20
MTBF	500,000H,MIL-HDBK-217F(25°C)
Life-time	Nominal life-time up to 100,000 h, see the description below for details
Vibration resistant	10~500Hz,5G 12min./1cycle,period for 72min. each along X,Y,Z axes
Acoustic Noise	<25dB(30cm, Normal operation)
Environmental protection	RoHS
Certifications and standards	
Certifications	CE, EL
Safety	EN 61347-1,EN 61347-2-13,EN 62493
EMC	EN IEC 55015,EN 61547,EN IEC 61000-3-2,EN 61000-3-3,ETSI EN 301 489-1,ETSI EN 301 489-17,ETSI EN 301 489-3
EL	Compatible IEC 61347-2- 13 Annex J, compatible with EN 60598-2-22 and EN 50172
RF	EN 62479,EN 50663,ETSI EN 300 328,ETSI EN 300 330

Remarks

- 1.By default, all parameter are measured at 230VAC input, 50Hz, full load and 25°C of ambient temperature.
- 2.The driver can not be installed inside the luminaire. when the driver is used with the light, the EMC of the whole light needs to be tested.

Technical data

Product model	BK-WAL040S-A1050AWCN
Output parameters	
Regulation method	Constant Current
Rated output current range	0.6-1.05A,see the operating window for details
Rated output voltage range	6-42VDC,see the operating window for details
Rated output power	40W Max,see the operating window for details
Output current adjustment	EasySet programming
Output current ripple LF	±2%
Output current accuracy	±2%
Linear regulation	±1%
Load regulation	±1%
No load output voltage	50VDC
Flicker-free(typical)	Flickering percent(IEEE 1789)=0.111%(100Hz), Flicker index(IEEE 1789)=0.000(100Hz), Pst LM = 0.02, SVM = 0.003, (The above parameters are obtained from testing the panel lights)
Input parameters	
Rated input voltage range	200-240VAC 200-240VDC
Input voltage range	180-264VAC 180-264VDC
Input voltage shock	<380 V AC
Input current	<0.24A (Rated input voltage)
Input frequency	0/50/60Hz
Input PF/Input DF(typical)	PF: 0.97, DF:0.97 ,see the electrical values below for details
Input THD(typical)	8.5% ,see the electrical values below for details
Efficiency(typical)	89% ,see the electrical values below for details
In-rush current(typical)	7.1A peak ,186us duration(50 % Ipeak), see the description below for details
Switching cycles	> 100,000 switching cycles
Power consumption(typical)	Full load(Pin):45.7W, No load(Pno): N/A, On stand-by(Psb) : <0.5W, Network stand-by(Pnet) : N/A
Safety	
Withstand voltage	I/P-O/P(LED):3750V AC
Mains surge capability	L-N:2KV(90°/270° , 5 times each with an interval of 60s)(Performance criterion:A)
Leakage current(typical)	0.33mA
Isolation resistance	I/P-O/P:100MΩ/500Vdc/25°C/70% RH
Wireless features	
Control system	Casambi Ready
Bluetooth version	Bluetooth 5.3
Transmission power	8 dBm
Reception sensitivity	-96dBm
Frequency range:	2.402 – 2.480 GHz
Dimming output	
Dimming range	1-100%
Dimming drive mode	AM(amplitude modulation)
Emergency support	
Central emergency system	Supported
Self-contained emergency	Supported
Environment & Life time	
Operating temperature	Ta=-20-45°C
Case temperature	Tc=90°C
Operating humidity	5-85% RH, not condensed
Storage temp./humidity	-40-80°C, 5-85% RH, not condensed
IP rating	IP20
MTBF	500,000H,MIL-HDBK-217F(25°C)
Life-time	Nominal life-time up to 100,000 h, see the description below for details
Vibration resistant	10~500Hz,5G 12min./1cycle,period for 72min. each along X,Y,Z axes
Acoustic Noise	<25dB(30cm, Normal operation)
Environmental protection	RoHS
Certifications and standards	
Certifications	CE, EL
Safety	EN 61347-1,EN 61347-2-13,EN 62493
EMC	EN IEC 55015,EN 61547,EN IEC 61000-3-2,EN 61000-3-3,ETSI EN 301 489-1,ETSI EN 301 489-17,ETSI EN 301 489-3
EL	Compatible IEC 61347-2- 13 Annex J, compatible with EN 60598-2-22 and EN 50172
RF	EN 62479,EN 50663,ETSI EN 300 328,ETSI EN 300 330

Remarks

1.By default, all parameter are measured at 230VAC input, 50Hz, full load and 25°C of ambient temperature.

2.The driver can not be installed inside the luminaire. when the driver is used with the light, the EMC of the whole light needs to be tested.

Technical data

Product model	BK-WAL060S-A2000AWCN
Output parameters	
Regulation method	Constant Current
Rated output current range	0.8-2A,see the operating window for details
Rated output voltage range	6-42VDC,see the operating window for details
Rated output power	61.2W Max,see the operating window for details
Output current adjustment	EasySet programming
Output current ripple LF	±2%
Output current accuracy	±2%
Linear regulation	±1%
Load regulation	±1%
No load output voltage	50VDC
Flicker-free(typical)	Flickering percent(IEEE 1789)=0.129%(100Hz), Flicker index(IEEE 1789)=0.000(100Hz), Pst LM = 0.007, SVM = 0.003, (The above parameters are obtained from testing the panel lights)
Input parameters	
Rated input voltage range	200-240VAC 200-240VDC
Input voltage range	180-264VAC 180-264VDC
Input voltage shock	<380 V AC
Input current	<0.36A (Rated input voltage)
Input frequency	0/50/60Hz
Input PF/Input DF(typical)	PF: 0.97, DF:0.98 ,see the electrical values below for details
Input THD(typical)	7.5% ,see the electrical values below for details
Efficiency(typical)	90.5% ,see the electrical values below for details
In-rush current(typical)	14.1A peak ,194us duration(50 % Ipeak), see the description below for details
Switching cycles	> 100,000 switching cycles
Power consumption(typical)	Full load(Pin):66.5W, No load(Pno): N/A, On stand-by(Psb) : <0.5W, Network stand-by(Pnet) : N/A
Safety	
Withstand voltage	I/P-O/P(LED):3750V AC
Mains surge capability	L-N:2KV(90°/270° , 5 times each with an interval of 60s)(Performance criterion:A)
Leakage current(typical)	0.25mA
Isolation resistance	I/P-O/P:100MΩ/500Vdc/25°C/70% RH
Wireless features	
Control system	Casambi Ready
Bluetooth version	Bluetooth 5.3
Transmission power	8 dBm
Reception sensitivity	-96dBm
Frequency range:	2.402 – 2.480 GHz
Dimming output	
Dimming range	1-100%
Dimming drive mode	AM(amplitude modulation)
Emergency support	
Central emergency system	Supported
Self-contained emergency	Supported
Environment & Life time	
Operating temperature	Ta=-20-45°C
Case temperature	Tc=90°C
Operating humidity	5-85% RH, not condensed
Storage temp./humidity	-40-80°C, 5-85% RH, not condensed
IP rating	IP20
MTBF	500,000H,MIL-HDBK-217F(25°C)
Life-time	Nominal life-time up to 100,000 h, see the description below for details
Vibration resistant	10~500Hz,5G 12min./1cycle,period for 72min. each along X,Y,Z axes
Acoustic Noise	<25dB(30cm, Normal operation)
Environmental protection	RoHS
Certifications and standards	
Certifications	CE, EL
Safety	EN 61347-1,EN 61347-2-13,EN 62493
EMC	EN IEC 55015,EN 61547,EN IEC 61000-3-2,EN 61000-3-3,ETSI EN 301 489-1,ETSI EN 301 489-17,ETSI EN 301 489-3
EL	Compatible IEC 61347-2- 13 Annex J, compatible with EN 60598-2-22 and EN 50172
RF	EN 62479,EN 50663,ETSI EN 300 328,ETSI EN 300 330

Remarks

1.By default, all parameter are measured at 230VAC input, 50Hz, full load and 25°C of ambient temperature.

2.The driver can not be installed inside the luminaire. when the driver is used with the light, the EMC of the whole light needs to be tested.

Electrical values

BK-WAL022S-A0600AWCN

Efficiency vs load

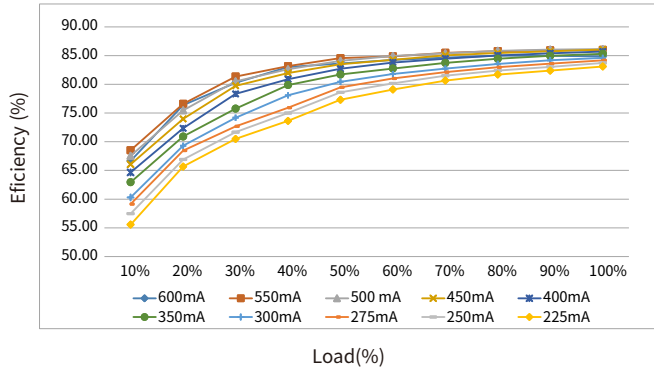

THD vs. Load

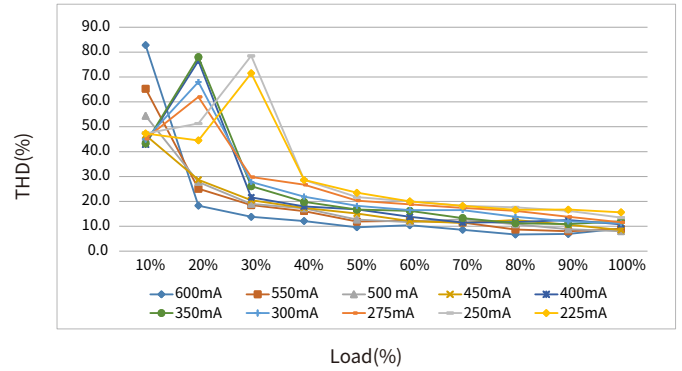

Power factor vs. Load

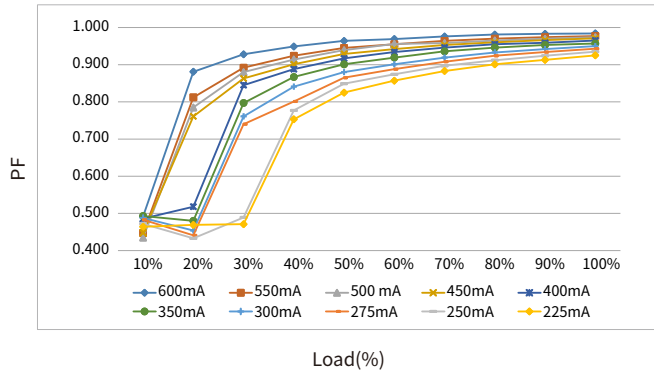

Displacement factor vs. Load

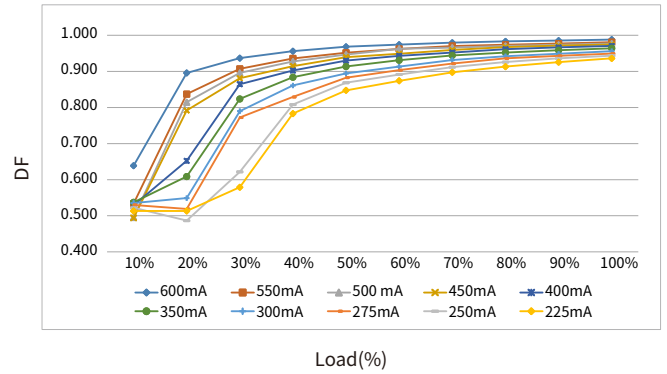

Operating window

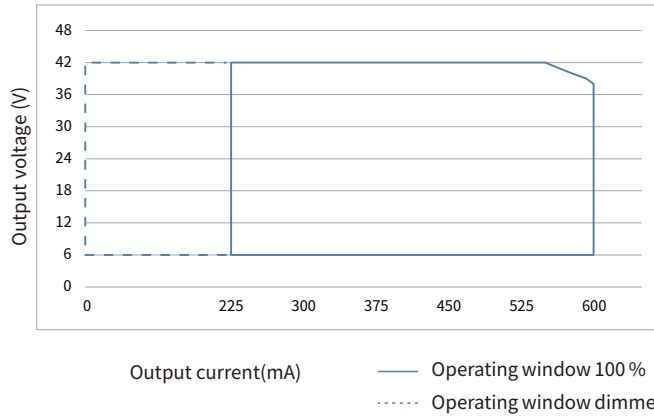

- Output voltage x output current = output power
- The minimum current step is 1mA, the minimum voltage step is 1V, the voltage range is 6-42V, the current range is 225-600mA, and the voltage and current can be set arbitrarily under the premise that the output power does not exceed 23.1W.

Expected life-time

Life-time vs. case temperature

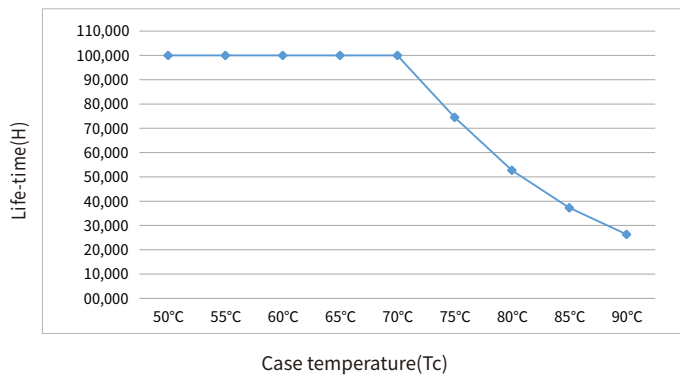

- The life-time of the LED driver is shown in the figure above (calculated based on the 90% survival rate).
- The relation of tc to ta temperature depends also on the luminaire design.

Electrical values

BK-WAL040S-A1050AWCN

Efficiency vs load

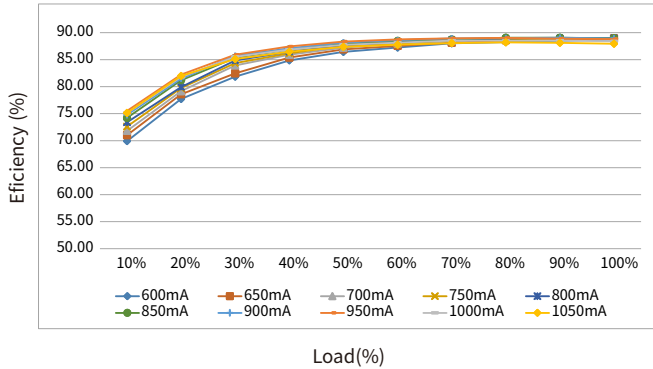

THD vs. Load

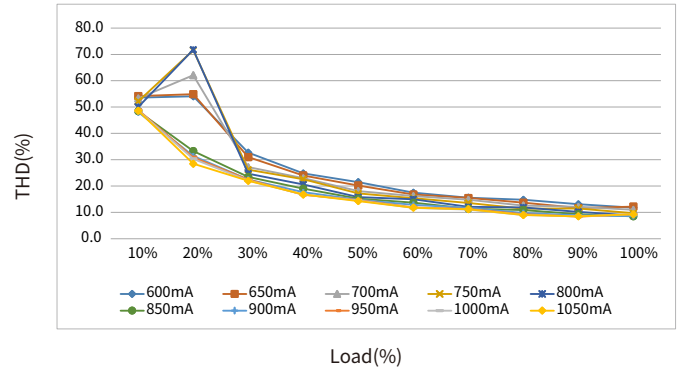

Power factor vs. Load

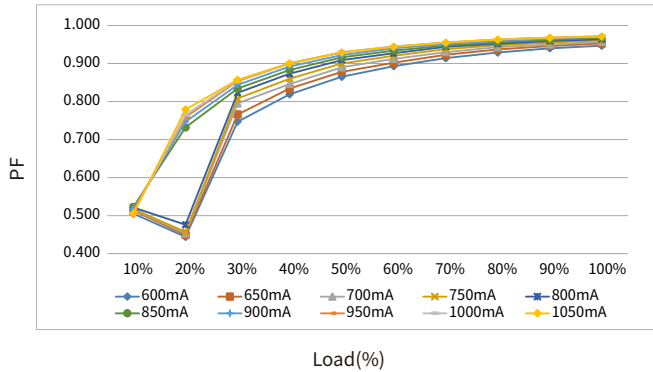

Displacement factor vs. Load

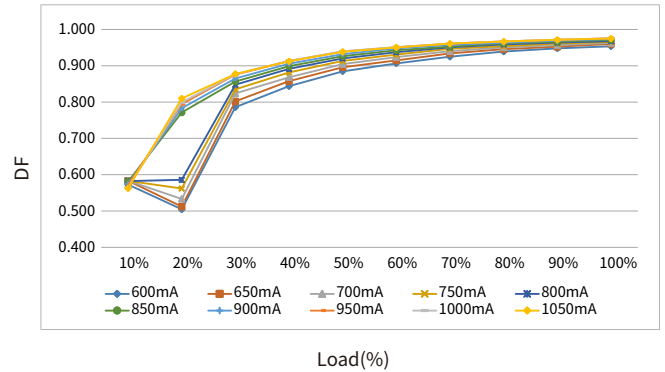

Operating window

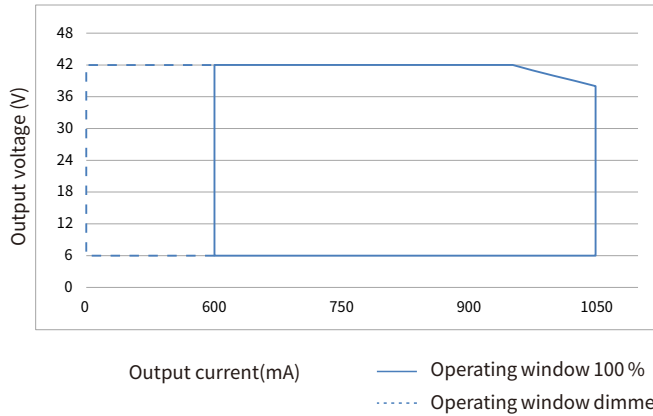

- Output voltage x output current = output power
- The minimum current step is 1mA, the minimum voltage step is 1V, the voltage range is 6-42V, the current range is 600-1050mA, and the voltage and current can be set arbitrarily under the premise that the output power does not exceed 40W.

Expected life-time

Life-time vs. case temperature

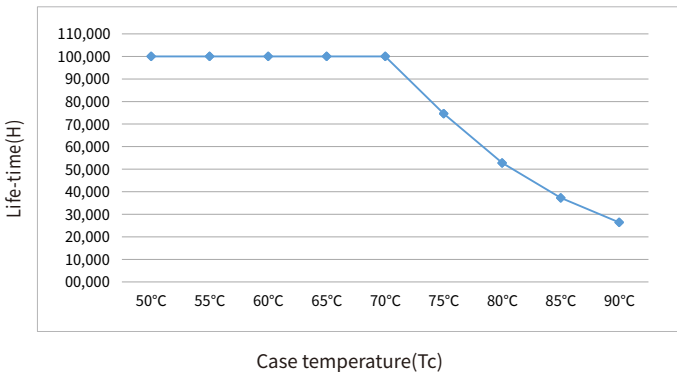

- The life-time of the LED driver is shown in the figure above (calculated based on the 90% survival rate).
- The relation of tc to ta temperature depends also on the luminaire design.

Electrical values

BK-WAL060S-A2000AWCN

Efficiency vs load

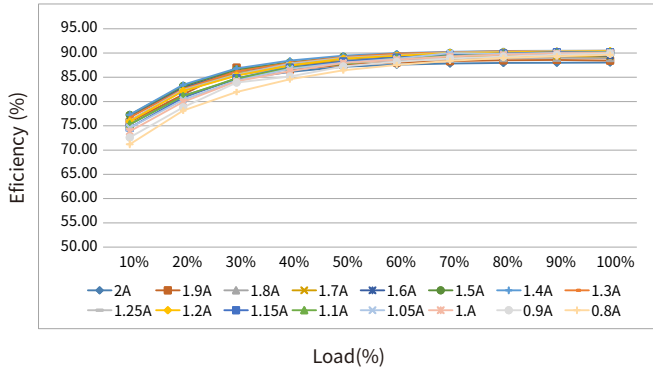

THD vs. Load

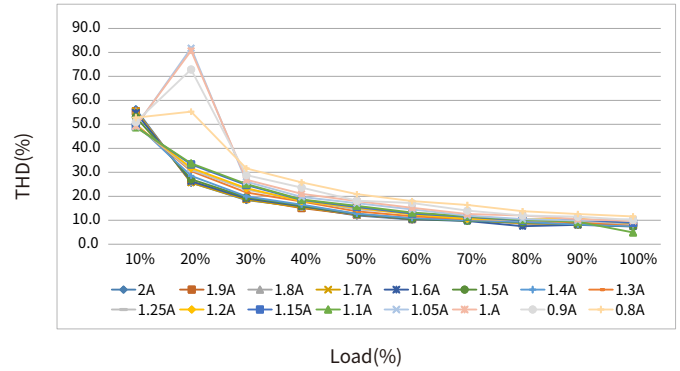

Power factor vs. Load

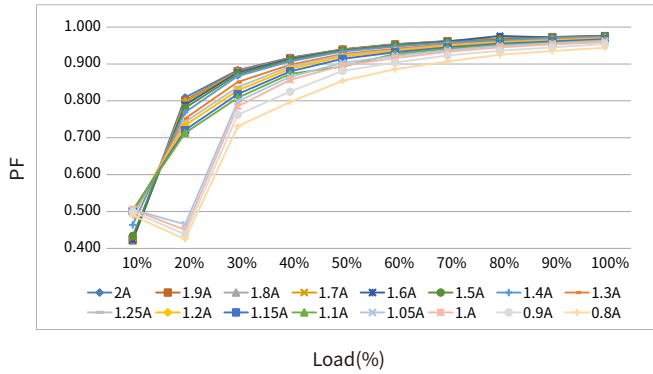

Displacement factor vs. Load

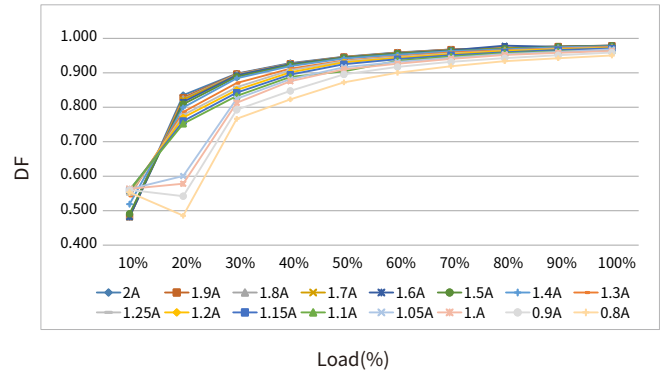

Operating window

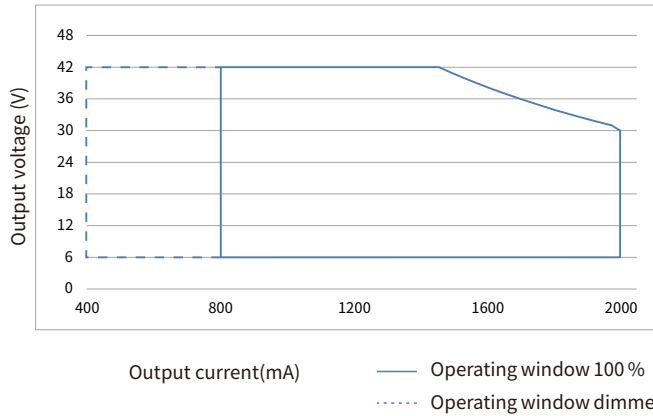

- Output voltage x output current = output power
- The minimum current step is 1mA, the minimum voltage step is 1V, the voltage range is 6-42V, the current range is 800-2000mA, and the voltage and current can be set arbitrarily under the premise that the output power does not exceed 61.2W.

Expected life-time

Life-time vs. case temperature

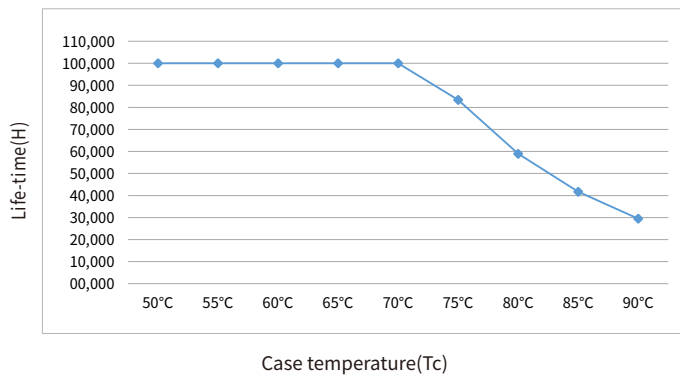

- The life-time of the LED driver is shown in the figure above (calculated based on the 90% survival rate).
- The relation of tc to ta temperature depends also on the luminaire design.

Surge

Model	Ipeak	Twidth	Condition	Relative number of MCB/pcs														
				B10	B13	B16	B20	B25	C10	C13	C16	C20	C25	D10	D13	D16	D20	D25
BK-WAL022S-A0600AWCN	6.28A	206us	AC 230V,Full load, Cold start,Ta≤30°C, MCB is not installed side by side	48	62	77	96	120	57	74	91	113	142	57	74	91	113	142
BK-WAL042S-A1050AWCN	7.1A	186us		33	44	54	67	84	33	44	54	67	84	33	44	54	67	84
BK-WAL060S-A2000AWCN	14.4A	194us		22	28	35	44	55	22	28	35	44	55	22	28	35	44	55

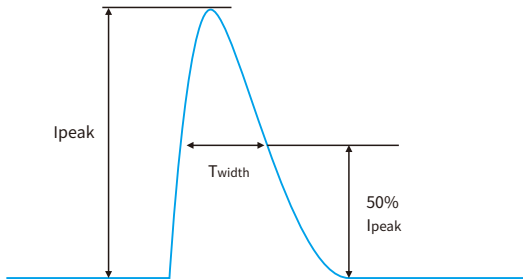

Remarks

- The number of drives mounted under different MCBs in the table is the maximum value. Please do not exceed this number during installation.
- Calculation uses typical values from ABB series S200 as a reference.
- Different brands and models of miniature circuit breakers, the number of drives mounted will be slightly different.
- If the ambient temperature of the MCB installation exceeds 30°C or multiple MCBs are installed side by side, the number of drives mounted will be reduced and the calculation needs to be recalculated.
- Electrician's usually consider Type B for household lighting and Type C for commercial lighting application.

Functions

Output short-circuit behaviour

- Output short-circuit will not damage the driver.
After removing the short circuit fault, the driver will automatically resume output.

Output overload protection

- The LED driver turns off the output if the output voltage range is exceeded.
The output will be activated again after restart the LED driver .

Output hot plug-in

In the following two cases,the LED driver will automatically turn off the output to protect the LED :

- When the driver is powered on first and the LED is connected later.
- When the driver is powered on,disconnected and conneced again.

The output will be activated again after restart of the LED driver .

Driver restart method

- Disconnect the AC of the driver and power it again.

Change profile method

- Make sure the driver is not connected to the network and change the profile in the 'Nearby Devices' option of the application.

Energy data viewing method

- Ensure that the driver is connected to the network and view Dali details in the application Driver Details page.

Adjustable output current (AOC)

- The output current of the driver can be adjusted within a certain range, and can be selected through the EasySet configuration software.

Constant light output (CLO)

- The luminous flux of a LED decreases constantly over the life-time.
- The CLO function ensures that the emitted luminous flux remains stable.For that purpose the LED current will increase continuously over the LED life-time.
- In EasySet configuration it is possible to select a start value(in percent) and an expected life-time.The LED driver adjusts the current afterwards automatically.

Emergency lighting(EL)

- The driver works normally under DC input.
- When the driver is applied in DC input, the positive pole of the DC cable should be connected to the ACL/DC+ terminal, and the negative pole of the DC cable should be connected to the ACN/DC- terminal. If the connection is reversed, the driver will not be damaged, but it will affect the EL function normal work.
- The output response action after DC input can be set through the EasySet configuration software.
Setting 1: When DC input, the output of the driver remains unchanged, and the dimming function responds normally.
Setting 2 (default,target brightness is 15%): When DC input, the output of the driver jumps to the set brightness, and the dimming function is invalid.

Configuration programming(EasySet)

- The programming configuration of the driver is realized using the BOKE EasySet programming suite and through the driver's NFC interface.
- Please see the "Device configuration" section.
- More information about the EasySet programming suite can be found at www.bokedriver.com.

Insulation between circuits

Isolation	Input	Output	Case
Input	-	Double	Double
Output	Double	-	Basic
Case	Double	Basic	-

Label

BK-WAL022S-A0600AWCN

BOKE Dimmable Constant Current LED Driver
MODEL: BK-WAL022S-A0600AWCN
 INPUT: 200-240V \approx 0/50/60Hz 0.14A Max. λ : 0.45C-0.95
 OUTPUT: 6-42V \approx 225-600mA 23.1W Max. 50VDC Max.
 For LED Modules use only
 www.bokedriver.com
 MADE IN CHINA

tc:90°C ta:50°C •tc

wire prep. 0.75-1.5mm²
 Preparation for input and output

■ ACL/DC+ 8-9mm

■ ACN/DC-

LED+ ■
 LED- ■
 wire prep. 0.5-1.0mm²

FLICKER FREE Energy Data EasySet area EasySet RoHS

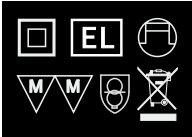

BK-WAL040S-A1050AWCN

BOKE Dimmable Constant Current LED Driver
MODEL: BK-WAL040S-A1050AWCN
 INPUT: 200-240V \approx 0/50/60Hz 0.24A Max. λ : 0.45C-0.95
 OUTPUT: 6-42V \approx 600-1050mA 40W Max. 50VDC Max.
 For LED Modules use only
 www.bokedriver.com
 MADE IN CHINA

tc:90°C ta:45°C

wire prep. 0.75-1.5mm²
 Preparation for input and output

■ ACL/DC+ 8-9mm

■ ACN/DC-

LED+ ■
 LED- ■
 wire prep. 0.5-1.0mm²

FLICKER FREE Energy Data EasySet area EasySet RoHS

BK-WAL060S-A2000AWCN

BOKE www.bokedriver.com
 Dimmable Constant Current LED Driver
MODEL: BK-WAL060S-A2000AWCN
 INPUT: 200-240V \approx 0/50/60Hz 0.36A Max. λ : 0.45C-0.95
 OUTPUT: 6-42V \approx 800-2000mA 61.2W Max. 50VDC Max.
 For LED Modules use only
 MADE IN CHINA

tc:90°C ta:45°C

wire prep. 0.75-1.5mm²
 Preparation for input and output

■ ACL/DC+ 8-9mm

■ ACN/DC- wire prep. 0.5-1.0mm²

LED+ ■

LED- ■

FLICKER FREE Energy Data EasySet area EasySet RoHS

Top view tc:90°C ta:45°C

Device configuration

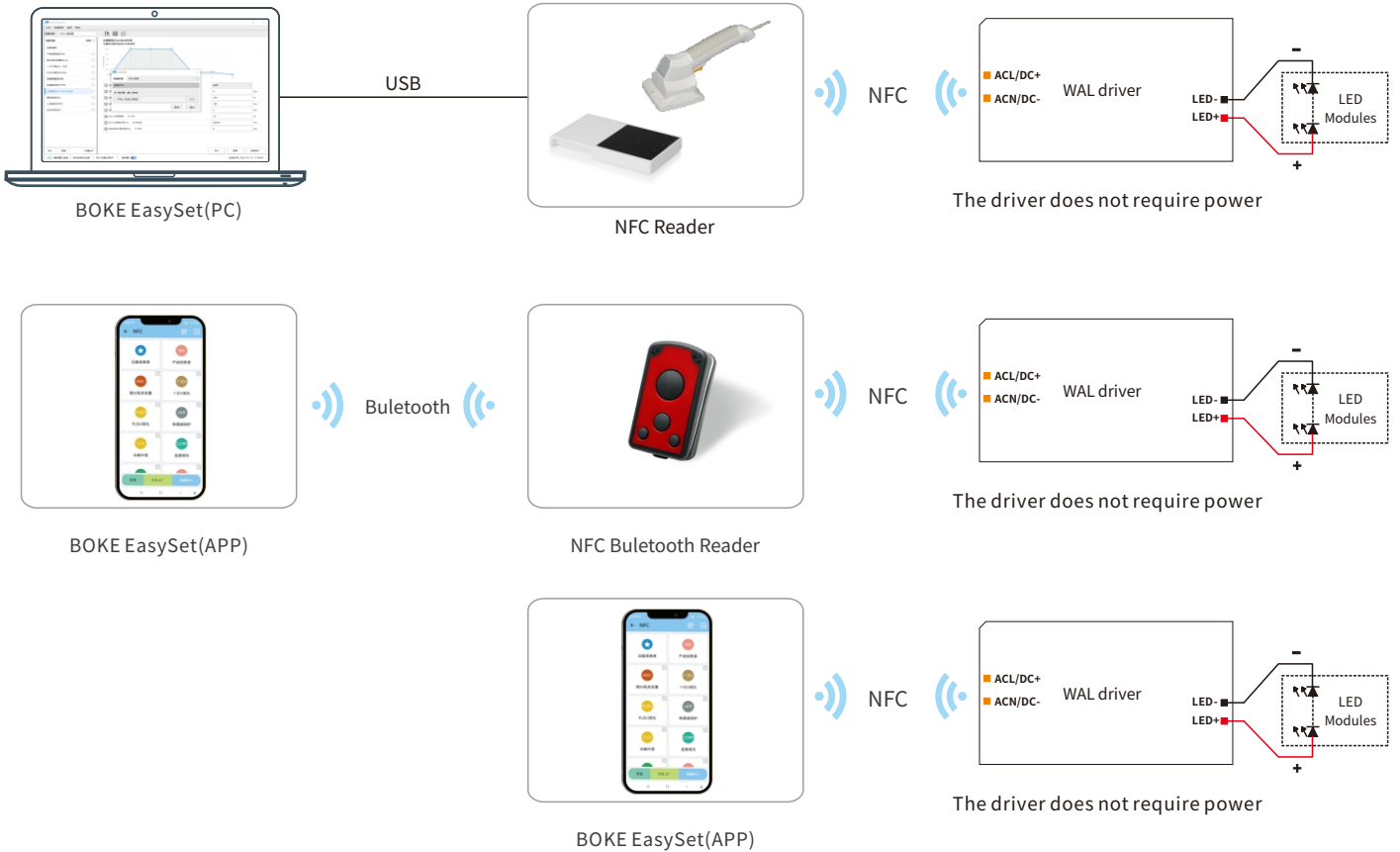

Software download(PC&mobile)



PC:Windows7/Windows10/Windows1132bit/64bit;
 Mobile:Androidsystem≥6.0, iosystem≥14.0.

Device configuration

Configure tools and software

Type	Name	Brand	Name	BOKE EasySet minimum version	
				PC	APP
Programmer	NFC desktop Reader	FEIG	CPR30+	V1.1.0	-
	NFC handheld Reader	FEIG	ID ISC-PRH101-USB	V1.2.2	-
	NFC Bluetooth Reader	FEIG	ID ECCO Smart HF-BLE	-	V1.0.0
Software	PC Software	BOKE	BOKE EasySet	V1.2.2	-
	APP	BOKE	BOKE EasySet	-	V1.0.0

Parameters configure

Configuration items	Factory settings	Parameter configuration	Read/Wirte
Product information	-	NO	Read Only
Adjustable output current(AOC)	Activated	YES	Read/Wirte
Emergency lighting(EL)	Activated	YES	Read/Wirte
Constant light output(CLO)	Deactivated	YES	Read/Wirte
Hot plug-in protection(HPP)	Deactivated	YES	Read/Wirte
Run-time(RT)		NO	Read Only
Other parameters		YES	

Note: The default factory mode of emergency lighting is derated mode, and the emergency brightness is 15%

Installation

Mechanical dimensions

Unit:mm

WAL022S-A

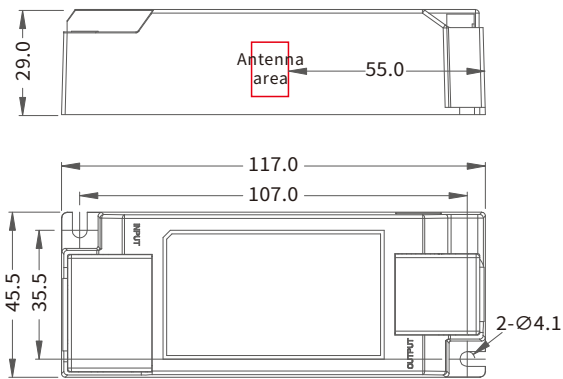

WAL040S-A

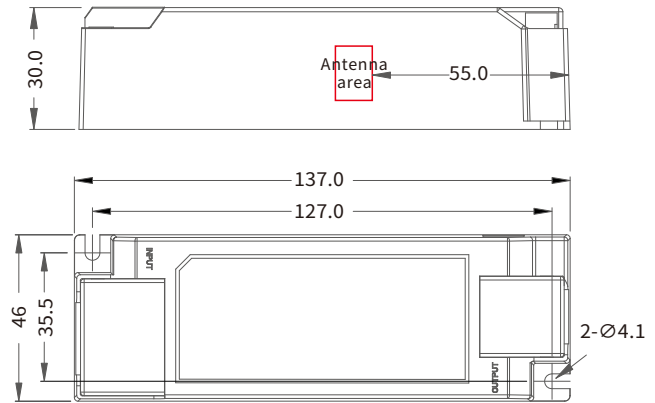

WAL060S-A

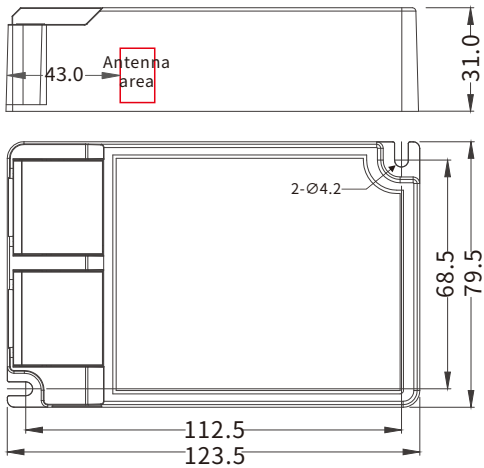

INPUT

Numbering	function	colour
1	ACL/DC+	orange
2	ACN/DC-	orange

Input wire

0.75-1.5mm²

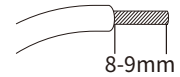

OUTPUT

Numbering	function	colour
1	LED-	black
2	LED+	red

Output wire

0.5-1.0mm²

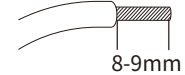

Installation note

Hot plug-in

- Hot plug-in is not supported due to residual output voltage of > 0 V.
- If a LED load is connected the device has to be restarted.
- Restart can be done by repowering the driver.

Wiring guidelines

- All connections must be kept as short as possible to ensure good EMI behaviour.
- Mains leads should be kept apart from LED Driver and other leads (ideally 5 – 10 cm distance)
- Max. length of output wires is 2 m.
- Incorrect wiring can damage LED modules.

Replace LED module

1. Mains off
2. Remove LED module
3. Wait more than 5 seconds
4. Connect LED module again

Adaptive Casambi network specification

- The driver supports use in both Evolution networks and Classic networks(recommend to use Evolution networks).
- Evolution networks support up to 250 nodes, while Classic networks support up to 127 nodes.
- Supports Casambi wireless Long Range (LR) mode network, supports LR device have longer coverage in all network modes.

Installation requirements

- The driver should preferably be installed in an environment without metal obstacles or without materials that severely weaken RF signals.
- Please do not place the driver in an environment completely surrounded by metal parts, as radio signals cannot pass through metal.
- The distance between driver should not exceed 40 meters; if there are partitions in between, the distance may be shortened, as shown in Figure 1.
- If there are many wireless communication devices (such as WiFi, or other Bluetooth devices) around the driver, the connection distance between two nodes will be greatly affected.
- Do not route cables near the antenna area of the driver (such as high-voltage input lines, LED power lines) to avoid signal interference.
- The driver should be kept at a certain distance from the ground; the recommended spacing should be $\geq 100\text{cm}$ to avoid signal interference, as shown in Figure 2.
- The driver should be kept at a certain distance from large metal objects; the recommended spacing should be $\geq 15\text{cm}$ to avoid signal interference, as shown in Figure 3.
- The driver should be kept at a certain distance from beams, walls, etc.; the recommended spacing should be $>15\text{cm}$ to avoid signal interference, as shown in Figure 4.
- The communication signal range of the driver depends on the surrounding environment, such as light fixtures, building structures, furniture, or people. Communication testing should be conducted during installation.

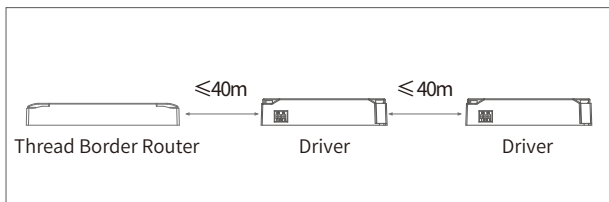

Figure 1

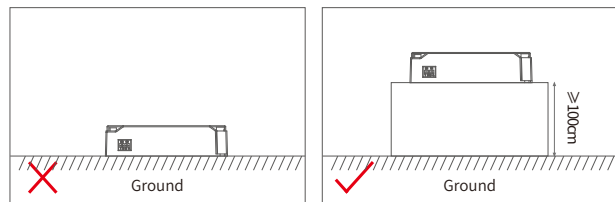

Figure 2

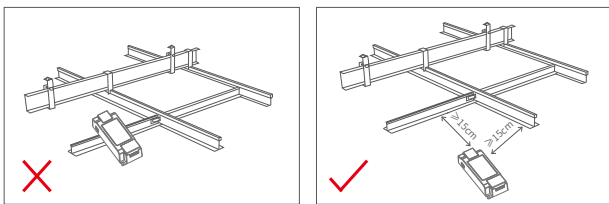

Figure 3

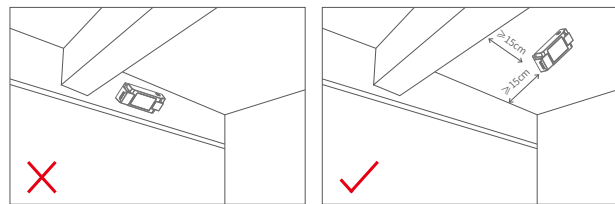

Figure 4

- The driver should be installed in a dry, acid-free, oil-free, fat-free environment.
- The ambient temperature of the driver should not exceed the value of T_a at any time.
- The driver should be lower than the temperature of T_a .
- The installation environment of the driver must comply with its supported IP protection level.
- The driver should be kept at a certain distance from the heating body (such as the luminaire radiator), and the recommended interval distance should be $\geq 7\text{cm}$, as shown in Figure 5.
- A certain distance should be maintained between the driver, and the recommended distance should be $\geq 15\text{cm}$ to avoid affecting the heat dissipation and service life of the product, as shown in Figure 6.

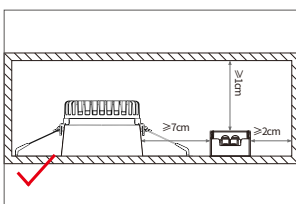

Figure 5

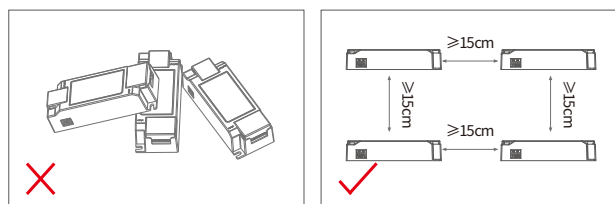
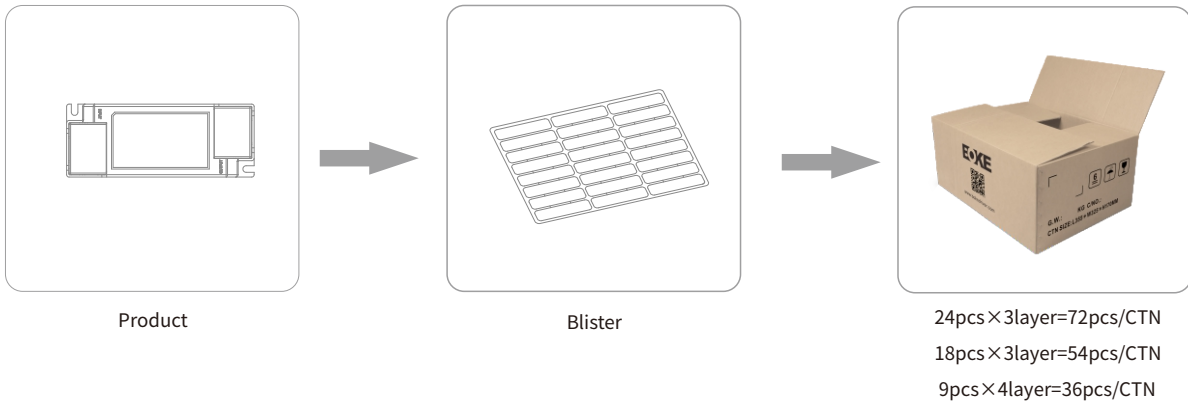

Figure 6

Packaging

Optional 1: factory default



Model	Product size	Weight	Blister size	Carton size	Qty/carton	N.W	G.W
WAL022S-A	L117*W45.5*H29mm	110g	L430*W340*H47mm	L450*W350*H180mm	72pcs	7.92kg	8.90kg
WAL040S-A	L137*W46*H30mm	150g	L430*W340*H48mm	L450*W350*H180mm	54pcs	8.10kg	9.21kg
WAL060S-A	L123*W78.5*H31mm	240g	L435*W345*H40mm	L450*W350*H180mm	36pcs	8.64kg	9.84kg

Optional 2:



Model	Product size	Weight	Packaging size	Carton size	Qty/carton	N.W	G.W
WAL022S-A	L117*W45.5*H29mm	110g	L140*W35*H50mm	L345*W310*H170mm	54pcs	5.94kg	7.38kg
WAL040S-A	L137*W46*H30mm	150g	L160*W35*H55mm	L335*W300*H170mm	48pcs	7.20kg	8.60kg
WAL060S-A	L123*W79.5*H31mm	240g	L140*W40*H100mm	L380*W295*H220mm	36pcs	8.64kg	9.84kg

Additional information

1. This product can only be used outside the light body, Can not be used inside of the light, and it must be used within the specified working environment.
2. The life and MTBF of the product are for reference only, and do not represent a warranty statement.
3. For more information, please send an email to info@bokedriver.com.